

COMBIMASS[®]

Technical data
COMBIMASS[®] compact

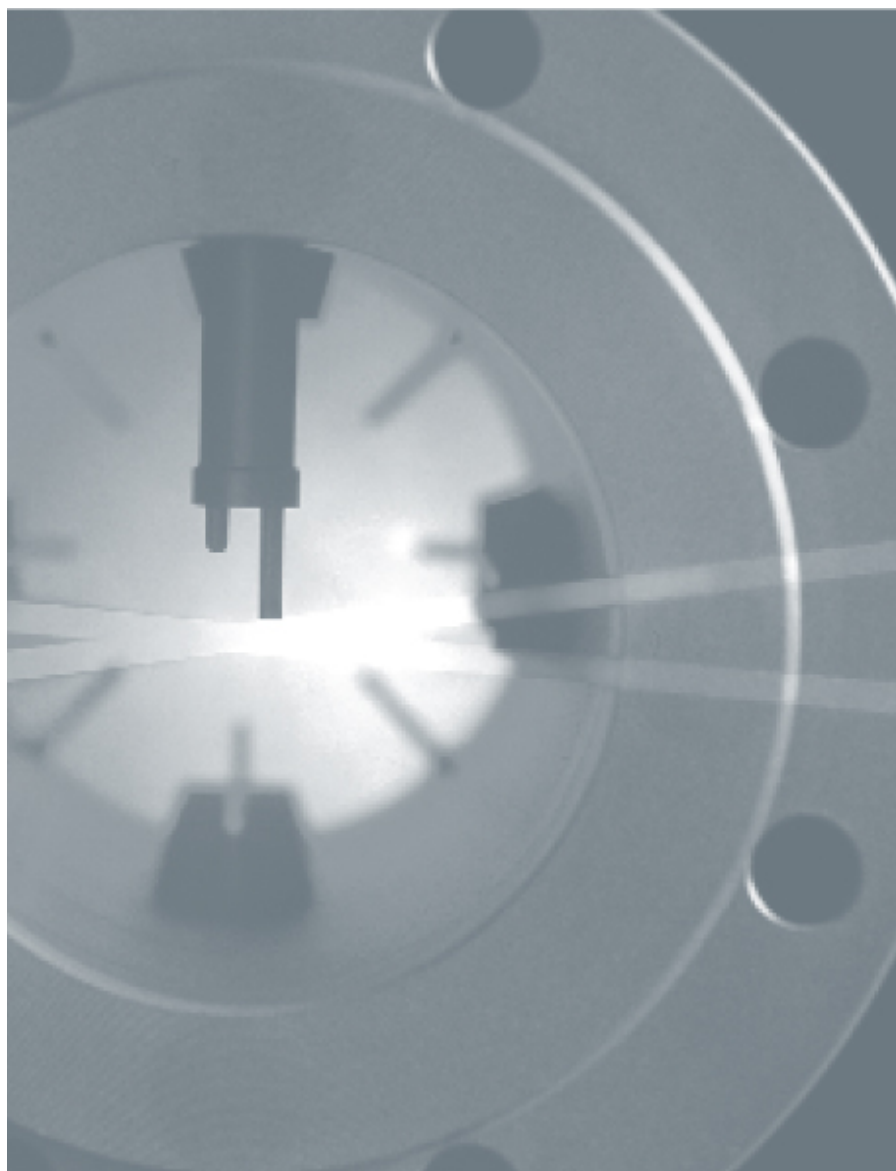

THE SYSTEM

The COMBIMASS[®]compact series of gas mass flow meters are field transmitters for flow rate measurement. They are especially designed for process applications at temperatures of up to 1100°C and operating pressures of up to 100 bars. Optionally, the units are available in explosion-proof versions for Zone 1 or Zone 0. The flow transmitters apply thermal dispersion technology in order to measure directly the normal volumetric or gas mass flow, regardless of the operating pressure and temperature of the medium.

All units of the COMBIMASS[®] series are characterized by high-performance digital signal processing. Important features of the transmitter electronics for the purposes of practical operation are the temperature compensation and the opportunity to select different measuring modes (choice between constant current or constant temperature principle). For operation of the flow meters at higher ambient temperatures, all transmitters of the COMBIMASS[®]compact series are optionally available with hybrid ceramic circuitry.

The electronics of the COMBIMASS[®]compact is located in a compression-proof dual compartment stainless steel enclosure. The slewable cable gland for easy installation is ideally suited for outside operation of the flow transmitter. Optionally a 10 digits LED display with control panel is available for indication of actual flow rate or totalized flow as well as for field programming of the flow meter.

For transmission of the flow signal an isolated 4-20 mA analog output as well as a field selectable pulse output are available. For intrinsically safe operation a dedicated process interface module has been developed for the power supply of the flow transmitter. In such a case, the signal output is done via an I/O module installed downstream of the process interface module. The circuitry of the process interface module and the I/O module is located in a top hat rail housing for easy switch cabinet assembly. Also an optionally available graphic display can be installed there.

The flow transmitter can be combined with a wide range of different sensors of the COMBIMASS[®] family and assembled individually according to the specific application. Each flow meter will be tested prior to shipment and calibrated at our CAMASS[®] calibration centre under actual operating conditions.

SMART FEATURES

- Thermal flow meter for direct measurement of normal volumetric or gas mass flows
- Flow rate measurement unaffected by pressure and temperature fluctuations
- Pressure-proof dual compartment stainless steel enclosure
- Slewable packing gland avoids moisture permeation in outside installations
- Compact and rugged design for exceptional reliability
- Easy to install and service
- Unmatched accuracy due to digital signal processing
- Temperature compensated flow rate measurement
- Choice of different measuring modes
- Available with hybrid ceramic circuitry for operation at ambient temperatures up to 140°C
- Expandable due to modular design
- Wide range of different sensors for each specific application
- Suitable for process temperatures of up to 1100°C
- EEx [ed] Zone 1 / EEx [ia] Zone 0 optionally available

APPLICATIONS VERSATILITY

- Air and technical gases
- Combustion gases such as methane, propane, natural gas, etc.
- Waste gas measurement, especially at high process temperatures
- Combustion air in incineration plants
- Biogas in wastewater and environmental installations
- Highly corrosive, explosive and flammable gases
- Gases at extreme process conditions
- Process gases such as acetylene, H₂, phosgene, ozone, etc.
- Gases and gas mixtures of known composition

SPECIFICATIONS

SPECIFICATIONS

Measuring principle	Gas flow measurement based on thermal dispersion technology
Applications	Compressed air, air, technical gases, inert gases, supply gases, combustion gases, process gases, explosive and flammable gases, dirty and moist gases, gases at extreme process temperatures and pressures, gases and gas mixtures of known composition, depending on choice of sensor
Measured parameter	<ul style="list-style-type: none"> ■ Gas mass flow [kg/h] ■ Normal volumetric flow [Nm³/h] ■ Normal flow velocity [Nm/s]
Signal processing	Microprocessor based, fully digital signal processing
Measuring modes	<p>Constant current or constant temperature principle</p> <p><u>Note:</u> The measuring mode will be selected by our qualified technicians depending on the application requirements during calibration of the flow meter and may not be changed by the operator.</p>
Calibration	One calibration group with advanced temperature compensation
Enclosure	Pressure proof dual compartment enclosure, 1.4571, Ø 62 mm
Protection class	IP 65 / IP 68
Explosion protection	<p>Approvals according to ATEX (optional):</p> <ul style="list-style-type: none"> ■ EEx [ed] – Zone 1 ■ EEx [ia] – Zone 0
Ambient conditions	<p>Ambient temperature -40°C to 80°C (standard electronics), Ambient temperature -40°C bis 140°C (hybrid ceramic circuitry – optional), Relative humidity 80%</p>

SPECIFICATIONS

Power supply	18 – 36 VDC Power supply via standard supply units possible For intrinsically safe operation – EEx [ia] – power supply via process interface module
Power consumption	max. 1,1 Watt
Reproducibility (electronics)	0,075% of reading
System accuracy (electronics)	0,2% of reading + 0,025% of full scale
Measuring accuracy (depending on application and type of calibration)	2% of reading + 0,1% of full scale (standard applications) 2% of reading + 0,2% of full scale (extreme applications) 1% of reading + 0,1% of full scale (optional – please, call factory)
Flow range (1013 mbar, 0°C)	0,08 m/s – 46 Nm/s (standard) 0,08 m/s – 400 Nm/s (optional)
Turndown ratio	10 : 1 up to 1000 : 1
Field display / control (optional)	<ul style="list-style-type: none"> ▪ 10 digits, alphanumeric LED display for field indication of flow rate or totalized flow ▪ Integrated totalizer ▪ Control pad for field programming of the flow meter using a magnetic pin ▪ Easy-to-use menu for transmitter set-up
Graphic display (optional)	<ul style="list-style-type: none"> ▪ Remote graphic display (wall or switch cabinet mounting) ▪ Simultaneous indication of flow rate and totalized flow ▪ Integrated totalizer ▪ Touch pad for easy programming of the flow meter ▪ Easy-to-use menu for transmitter set-up
Signal output (isolated)	<p>1 x analog output: 4-20 mA, active load < 400 Ohm 10 bit resolution</p> <p>1 x impulse output: field selectable max. 30 impulse/s</p>

SPECIFICATIONS

Choice of sensors	Transmitter can be combined with different sensors of the COMBIMASS [®] series:
	Sensor geometry: 1-pin type, 1½-pin type, 2-pin type, special geometries
	Process temperature: max. 1100°C
	Operating pressure: max. 100 bar
	Diameter of sensor rod: 12 mm, 18 mm, 25 mm
	Materials: 1.4571 (standard)
	1.3981 (standard for process temperatures > 370°C)
	1.4435, HC 22, special materials (optional)
	Approvals: PED test certificate, modules B+F or module G (optional)
	Certificates: 3.1B material certificate (optional)
	Type of flow element: Insertion flow element
	Inline flow element
	Process connections: Compression fitting, butt weld,
	screw, flange (DIN, ANSI),
	retractable packing gland
	Hot tapping: manually actuated with ball valve,
	lead-screw actuated with ball valve,
	hydraulically actuated with ball valve,
	depending on the operating pressure of the medium

INLET AND OUTLET STRAIGHT PIPE RUNS

INLET AND OUTLET STRAIGHT PIPE RUNS

General information

To achieve high accuracy in flow rate measurement as specified, consideration of sufficient inlet and outlet straight pipe runs according to DIN ISO 5167-1 is crucial during installation of the flow transmitter. Reasonable measuring results can also be achieved with shortened inlet and outlet straight pipe runs according to the below specifications.

If sufficient inlet and outlet straight pipe runs are not available, please call factory. It might be possible to achieve the required measurement accuracy, if a special calibration can be carried out at our CAMASS[®] calibration centre by simulating the actual operating conditions, the range of flow rates and the piping.

Alternatively, the installation of a flow conditioner may allow to achieve accurate measuring results when space is restricted.

Reduction piece

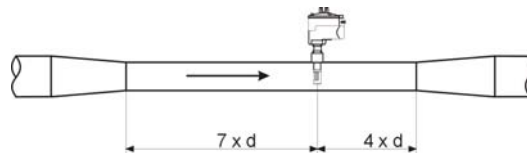

Extension piece

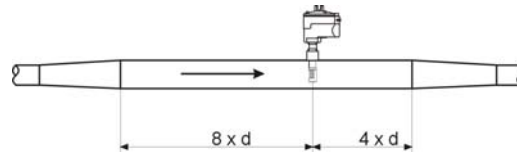

One 90° elbow

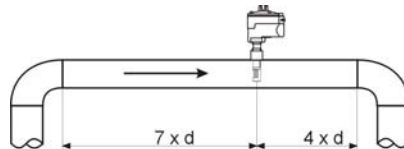

Two 90° elbows in one plane

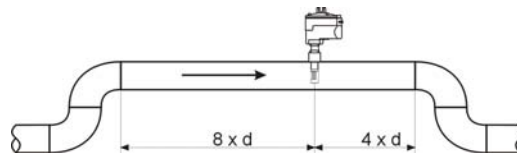

Two 90° elbows in two planes

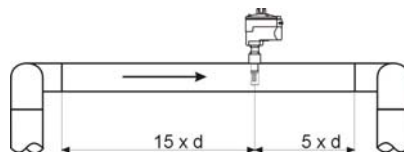

Three 90° elbows in three planes

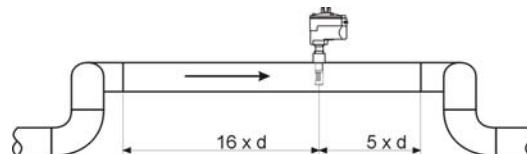

DIMENSIONS

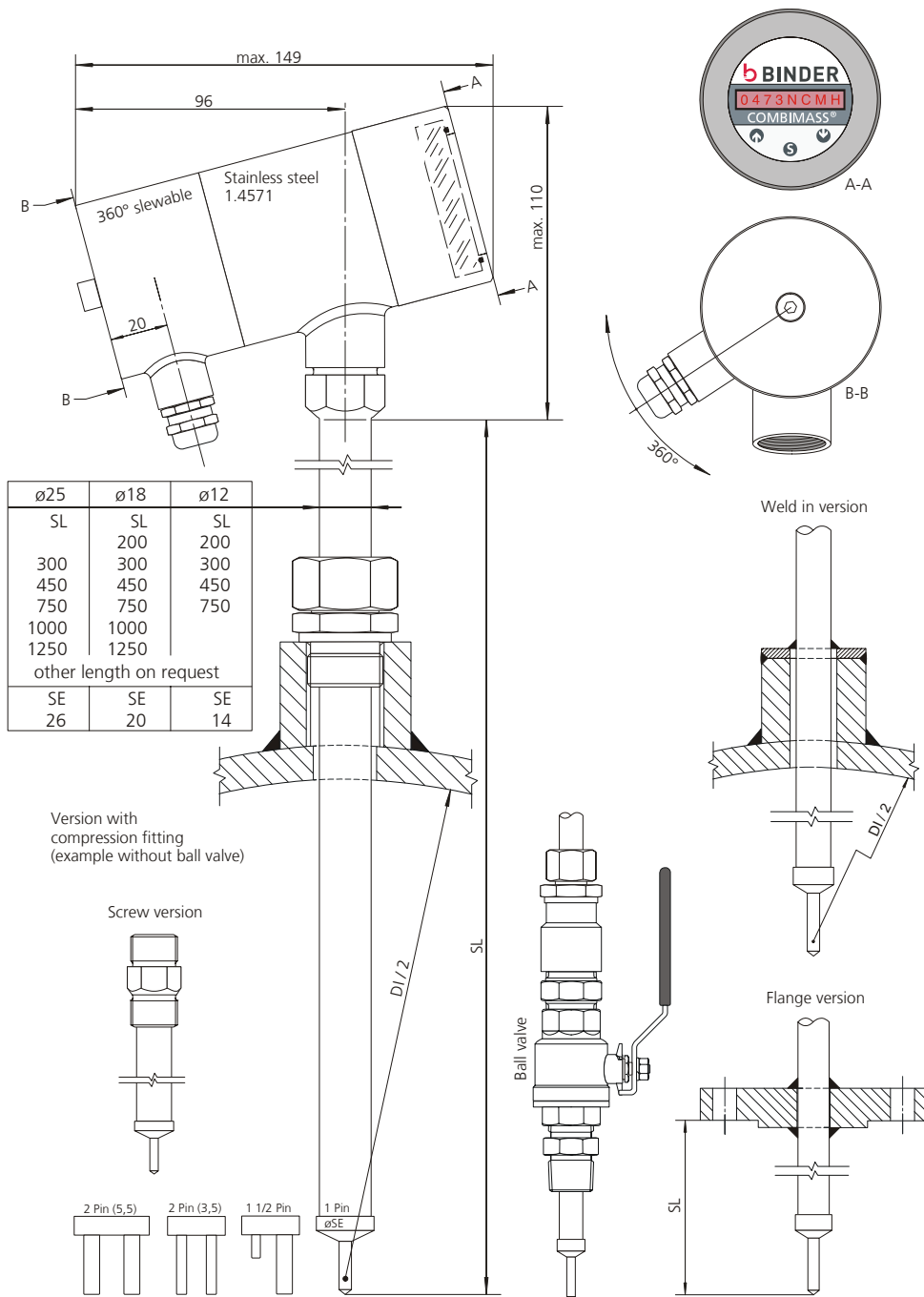

IMPRESSUM

BINDER GmbH
Buchbrunnenweg 18
89081 Ulm, Germany
Tel. +49 731 18998-0
Fax +49 731 18998-88

info@binder-flow.com
www.binder-flow.com

Technical data
TD_COMBIMASS compact_E_2004-03